

**SPRING HANGERS,
SPRING SUPPORTS**

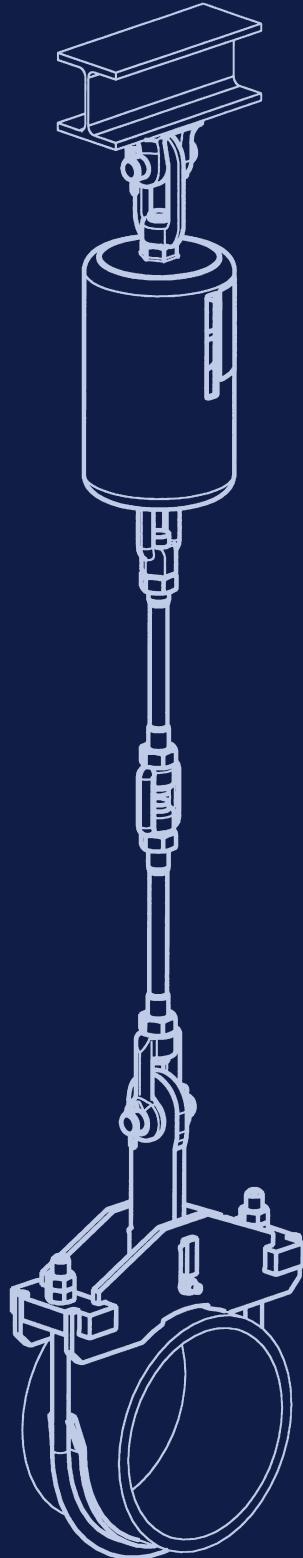

**PRODUCT
GROUP**

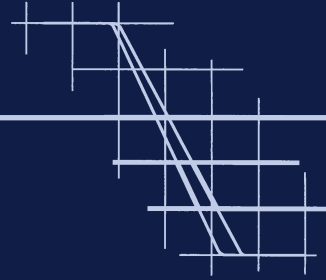
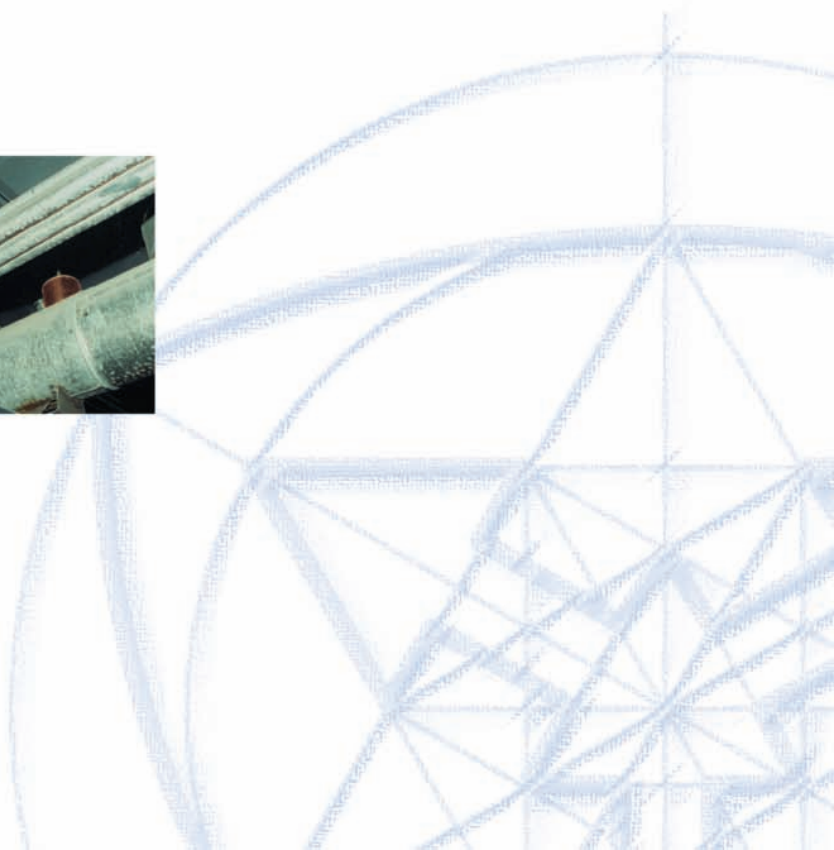
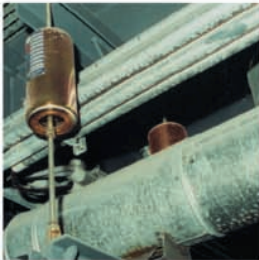
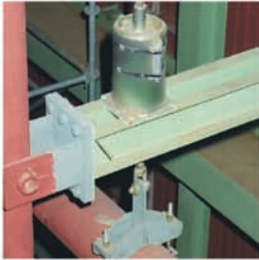

VARIABLE SPRING ELEMENTS

2

CONTENTS

PAGE

Spring hangers, spring supports, sway braces _____	2.1
Load table for spring hangers, spring supports and other spring elements _____	2.3
Spring hangers, type 21 _____	2.5
Spring hangers, type 22 _____	2.6
Spring hangers (seated), type 25 _____	2.7
Spring hangers (seated), type 26 _____	2.8
Spring supports, type 29 _____	2.9
Spring supports, type 28 _____	2.10
Angulating spring supports, type 20 _____	2.11
Spring hanger trapezes, type 79 _____	2.12
Sway braces, type 27 _____	2.13
Installation and operating instructions _____	2.15

0

1

PRODUCT
GROUP 2

3

4

5

6

7

8

9

SPRING HANGERS SPRING SUPPORTS

To prevent constraints in the system, thermal expansion in the piping and other piping components must not be hindered. The piping must therefore be supported in a correspondingly elastic manner.

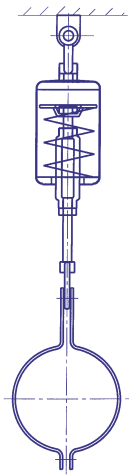

Spring hanger, type 21

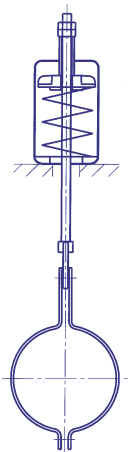

Spring hanger, type 25

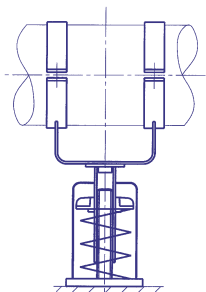

Spring support, type 29

Spring elements

To compensate for slight vertical displacements in the piping, spring components are used as supports. The functioning of these components is based on preset helical coil springs which exert a variable supporting load over the whole range of movement corresponding to the given spring characteristics. Load variations resulting from this are limited through corresponding specifications based on stress calculations for the piping - this depends on the sensitivity of the system.

The fundamental principles relevant for the function of the spring components are found in the **MSS SP 58** and **VGB R 510 L** guidelines. See **Technical Specifications**, page 0.5.

LISEGA spring hangers

Various versions of spring elements, ideally suited to whatever structural requirements exist, are available. The optimum choice depends on the installation situation.

Spring hangers, type 21

This type, the one most frequently used, is fitted with an upper connection for suspension. It is installed wherever the surrounding location offers a suitable connection point and sufficient space. The upper connections can be universally adapted with standard components to any given situation.



Spring hangers, type 25

This type is frequently used for its simple installation, just seating it on the existing steel. The connection is made by a rod passing through the unit.



Spring supports, type 29

If the installation location does not permit suspension, then this model is a suitable alternative as a „prop“ support. Where there is considerable horizontal displacement of the support load, and steel slides on steel, lateral forces can under certain conditions have an adverse effect on the operation of the support system. To take precautions against this, the use of PTFE bearings is recommended. In this case the counter bearing should have a stainless steel surface.



▶ Type 29 with PTFE slide plate.



Load % Nominal load	Travel range 1				Travel range 2				Travel range 3			
	40%	60%	80%	100%	40%	60%	80%	100%	40%	60%	80%	100%
Type												
29 C. 19												
29 D. 19												
29 1. 18												
29 2. 18												
29 3. 18												
29 4. 18												
29 5. 18												
29 6. 18												
29 7. 18												
29 8. 18												
29 9. 18												

Recommended use of PTFE slide plates for spring supports type 29

Angulating spring supports, type 20

Unlike the spring support type 29, horizontal displacement can be taken up almost free of lateral forces by this design.

This way that constraining frictional forces are completely excluded at all levels of movement, vertical and horizontal.



Sway braces, type 27

These particular components act both in tension and compression and are used to stabilize the piping and other plant components. An additional damping effect is obtained at the same time. The connection parts correspond with those of Product Group 3.



With LISEGA sway braces, type 27, the following adjustments can be made:

- load presetting
- free stroke
- installation dimension

See also Installation and Operating Instructions, page 2.17

Load setting and blocking

Spring hangers and supports are preset at the works to the installation load and blocked in both directions of movement. Blocking is necessary to take up additional loads during pickling, flushing, or hydrostatic tests. The factory settings are carried out on electronically controlled test benches:

- with spring hangers, values set at the factory are stamped onto a riveted name plate.
- the installation position is marked on the travel scale.
- cold and hot settings are marked on the travel scale with a white and red sticker respectively.

- the blocking device can be blocked in any position. The blocking pieces can be reinserted in any required position.

Spring hangers and supports should be set in such a way that the spring load and the piping weight correspond with the cold load position.

The corresponding hot load position results from the theoretically determined pipe movement (travel) and the spring rate.

The load difference between the cold and hot positions acts on the piping as a reaction force and is limited by the relevant design specifications.

Generally, the max. permissible load deviation amounts to 25% of the operating load.

Above and beyond that, constant hangers exerting a **constant supporting** load over the whole travel range are to be used.

Selection of spring hangers

A decisive factor for the reaction force is the stiffness of the spring rate value of the respective coil springs. To cover the widest possible field of application using spring hangers, the load ranges are divided into 5 travel ranges.

Please see **Technical Specifications** page 0.13 for details of usage. See also the selection table, pages 2.3 and 2.4, as well as **Installation and Operating Instructions**, page 2.15.

Design related advantages

- no welding (Types 20, 21, 27)
- fully galvanized surfaces
- specially prerelaxed springs
- integrated tightening devices
- adjustable blocking system
- variable connection possibilities
- TÜV suitability test
- a wealth of experience from over a million applications

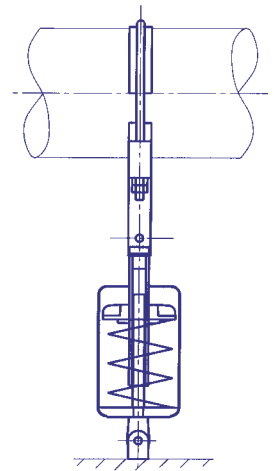

Angulating spring support, type 20

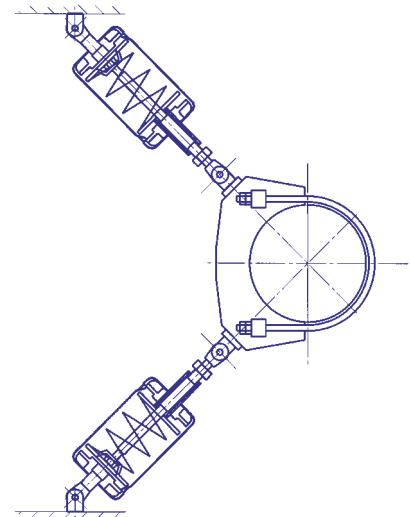

Sway brace, type 27 angulated arrangement

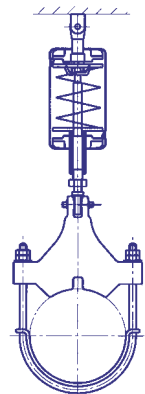

Sway brace, type 27 single arrangement

SELECTION OF SPRING ELEMENTS

SELECTION CRITERIA FOR SPRING HANGERS AND SUPPORTS

Permissible force variation

The permissible force variation between cold load (installation load) position to hot load (operating load) position is limited internationally by common specifications for pipe stress analysis to **max. 25% of the operating load.**

Maximum working travel

Additionally, to preclude functional impairment due to instability from extra long springs, a **working travel of maximum 50mm** should not be exceeded.

Spring rates

To cover as wide a field of applications as possible while adhering to these standards, LISEGA spring elements are divided into 5 travel ranges with correspondingly different spring rates.

Extra long springs

Travel ranges 4 & 5 relate to extra long springs and should only be used after technical evaluation of the whole situation, especially in sensitive piping systems.

Design types

The selection of the suitable design type depends upon the respective support configuration or installation situation.

Economical unit size

To find the most economical size, the following procedures apply:

Spring hangers type 21, Spring hangers type 25, Spring supports type 29, Angulating spring supports type 20

Travel range ①					Type number													
					21 C2 19	21 D. 19	21 1. 18	21 2. 18	21 3. 18	21 4. 18	21 5. 18	21 6. 18	21 7. 18	21 8. 18	21 9. 18			
						25 D. 19	25 1. 18	25 2. 18	25 3. 18	25 4. 18	25 5. 18	25 6. 18	25 7. 18	25 8. 18	25 9. 18			
					29 C2 19	29 D. 19	29 1. 18	29 2. 18	29 3. 18	29 4. 18	29 5. 18	29 6. 18	29 7. 18	29 8. 18	29 9. 18			
...1..	...2..	...3..	...4..	...5..	20 D2 19	20 12 14	20 22 14	20 32 14	20 42 14	20 52 14	20 62 14	20 72 14	20 82 14	20 92 14				
Working travel (mm)					Load (kN)													
0	0	0	0	0	0.04	0.12	0.41	0.83	1.66	3.33	6.66	13.33	20.00	26.66	33.33			
2.5	5	10	15	20	0.05	0.14	0.45	0.91	1.83	3.66	7.33	14.66	22.00	29.33	36.66			
5.0	10	20	30	40	0.06	0.16	0.50	1.00	2.00	4.00	8.00	16.00	24.00	32.00	40.00			
7.5	15	30	45	60	0.07	0.18	0.54	1.08	2.16	4.33	8.66	17.33	26.00	34.66	43.33			
10.0	20	40	60	80	0.08	0.20	0.58	1.16	2.33	4.66	9.33	18.66	28.00	37.33	46.66			
12.5	25	50	75	100	0.09	0.22	0.62	1.25	2.50	5.00	10.00	20.00	30.00	40.00	50.00			
15.0	30	60	90	120	0.10	0.24	0.66	1.33	2.66	5.33	10.66	21.33	32.00	42.66	53.33			
17.5	35	70	105	140	0.11	0.26	0.70	1.41	2.83	5.66	11.33	22.66	34.00	45.33	56.66			
20.0	40	80	120	160	0.12	0.28	0.75	1.50	3.00	6.00	12.00	24.00	36.00	48.00	60.00			
22.5	45	90	135	180	0.13	0.30	0.79	1.58	3.16	6.33	12.66	25.33	38.00	50.66	63.33			
25.0	50	100	150	200	0.14	0.32	0.83	1.66	3.33	6.66	13.33	26.66	40.00	53.33	66.66			
27.5	55	110	165	220	0.16	0.34	0.87	1.75	3.50	7.00	14.00	28.00	42.00	56.00	70.00			
30.0	60	120	180	240	0.17	0.36	0.91	1.83	3.66	7.33	14.66	29.33	44.00	58.66	73.33			
32.5	65	130	195	260	0.18	0.38	0.95	1.91	3.83	7.66	15.33	30.66	46.00	61.33	76.66			
35.0	70	140	210	280	0.19	0.40	1.00	2.00	4.00	8.00	16.00	32.00	48.00	64.00	80.00			
37.5	75	150	225	300	0.20	0.42	1.04	2.08	4.16	8.33	16.66	33.33	50.00	66.66	83.33			
40.0	80	160	240	320	0.21	0.44	1.08	2.16	4.33	8.66	17.33	34.66	52.00	69.33	86.66			
42.5	85	170	255	340	0.22	0.46	1.12	2.25	4.50	9.00	18.00	36.00	54.00	72.00	90.00			
45.0	90	180	270	360	0.23	0.48	1.16	2.33	4.66	9.33	18.66	37.33	56.00	74.66	93.33			
47.5	95	190	285	380	0.24	0.50	1.20	2.41	4.83	9.66	19.33	38.66	58.00	77.33	96.66			
50.0	100	200	300	400	0.25	0.52	1.25	2.50	5.00	10.00	20.00	40.00	60.00	80.00	100.00			
					Spring rate c (N/mm)													
										11.1	22.2	33.3	44.4	66.6	100.0	133.3	166.6	
										2.1	4.1	6.6	8.9	13.3	20.0	26.6	33.3	
										2.1	4.1	6.6	13.3	26.6	40.0	53.3	66.6	
										8.3	16.6	33.3	66.6	133.3	266.6	533.3	666.6	
										8.3	16.6	33.3	66.6	133.3	266.6	533.3	1066.6	1333.3

DETERMINATION OF THE MOST FAVORABLE SIZE

1. Selecting the ideal spring hanger

Example:

Operating load $F = 6000\text{N}$

Permissible deviation $p < 25\%$

Travel (up) $s = 15\text{mm}$

$$c \leq \frac{25\% \cdot 6000\text{N}}{15\text{mm} \cdot 100\%} = 100\text{N/mm}$$

Selection type 25 42 18

Spring rate $c = 66.6\text{N/mm}$

Cold load $F_K = 7000\text{N}$

2. Determination of the percentage of force variation

Example:

6000N operation load, travel 15mm (up)

A spring hanger type 25 42 18 was

selected with a spring rate

of $c = 66.6\text{N/mm}$

$$\frac{15\text{mm} \cdot 66.6\text{N/mm} \cdot 100\%}{6000\text{N}} = 16.65\%$$

Spring hangers type 22. Variable spring hanger for seating type 26, spring supports type 28

Travel range ①			Type number				
			22 1. 19	22 2. 19	22 3. 19	22 4. 19	22 5. 19
			26 1. 19	26 2. 19	26 3. 19	26 4. 19	26 5. 19
...1..	...2..	...3..	28 1. 19	28 2. 19	28 3. 19	28 4. 19	28 5. 19
Working travel (mm)			Load (kN)				
0	0	0	53.33	66.66	80.00	100.00	133.33
2.5	5	10	58.66	73.33	88.00	110.00	146.66
5.0	10	20	64.00	80.00	96.00	120.00	160.00
7.5	15	30	69.33	86.66	104.00	130.00	173.33
10.0	20	40	74.66	93.33	112.00	140.00	186.66
12.5	25	50	80.00	100.00	120.00	150.00	200.00
15.0	30	60	85.33	106.66	128.00	160.00	213.33
17.5	35	70	90.66	113.33	136.00	170.00	226.66
20.0	40	80	96.00	120.00	144.00	180.00	240.00
22.5	45	90	101.33	126.66	152.00	190.00	253.33
25.0	50	100	106.66	133.33	160.00	200.00	266.66
27.5	55	110	112.00	140.00	168.00	210.00	280.00
30.0	60	120	117.33	146.66	176.00	220.00	293.33
32.5	65	130	122.66	153.33	184.00	230.00	306.66
35.0	70	140	128.00	160.00	192.00	240.00	320.00
37.5	75	150	133.33	166.66	200.00	250.00	333.33
40.0	80	160	138.66	173.33	208.00	260.00	346.66
42.5	85	170	144.00	180.00	216.00	270.00	360.00
45.0	90	180	149.33	186.66	224.00	280.00	373.33
47.5	95	190	154.66	193.33	232.00	290.00	386.66
50.0	100	200	160.00	200.00	240.00	300.00	400.00
			Spring rate c (N/mm)				
			533.3	666.6	800	1000	1333.3
			1066.6	1333.3	1600	2000	2666.6
			2133.3	2666.6	3200	4000	5333.3

① Travel range = 4th digit of type designation
For availability of component type in the different travel ranges, see dimension table pages 2.5 to 2.11.

② The use of extra long springs is only to be recommended in limited cases because of the relatively large spring hysteresis.

SPRING HANGER TYPE 21

Spring hangers type 21 C2 19 to 21 95 18

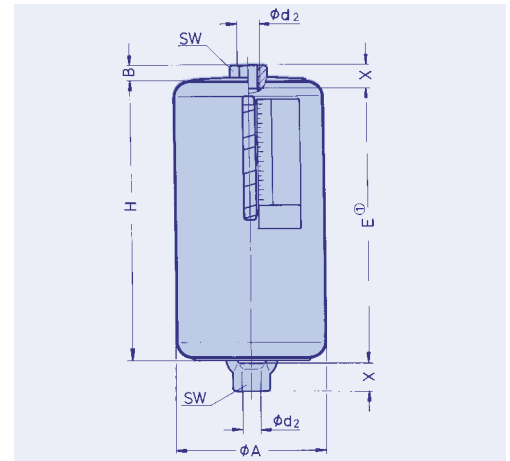

① Dim E increases under load by the corresponding spring travel (see load table on page 2.3).

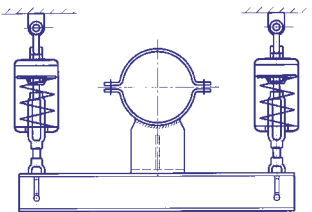

In restricted spaces, spring hangers can be installed with trapeze type 79. See page 2.12

Type	ØA	B	Ød2	E①	H	SW	X	Weight (kg)
21 C2 19	80	11	M10	205	205	19	15	1.9
21 D2 19	90	11	M10	250	245	19	15	3.0
21 D3 19	90	11	M10	475	470	19	15	5.0
21 11 18	90	11	M12	155	145	19	15	2.1
21 12 18	90	11	M12	250	245	19	15	3.1
21 13 18	90	11	M12	475	470	19	15	5.5
21 21 18	115	12	M12	155	150	19	15	3.8
21 22 18	115	12	M12	255	250	19	15	5.3
21 23 18	115	12	M12	475	460	19	15	8.6
21 31 18	115	13	M16	160	155	24	20	4.3
21 32 18	115	13	M16	255	250	24	20	6.0
21 33 18	115	13	M16	475	470	24	20	9.7
21 34 18	115	13	M16	840	725	24	20	14.0
21 41 18	155	17	M20	185	180	30	25	9.2
21 42 18	155	17	M20	290	290	30	25	12.8
21 43 18	155	17	M20	525	525	30	25	20.0
21 44 18	155	17	M20	920	800	30	25	29.0
21 51 18	180	21	M24	215	215	36	30	16.5
21 52 18	180	21	M24	305	305	36	30	20.5
21 53 18	180	21	M24	540	540	36	30	32.0
21 54 18	180	21	M24	1035	825	36	30	46.0
21 55 18	180	21	M24	1275	1065	36	30	57.0
21 61 18	220	24	M30	245	245	46	35	31.0
21 62 18	220	24	M30	360	360	46	35	40.0
21 63 18	220	24	M30	640	640	46	35	62.0
21 64 18	220	24	M30	1205	980	46	35	90.0
21 65 18	220	24	M30	1490	1265	46	35	114.0
21 71 18	245	30	M36	280	285	55	45	48.0
21 72 18	245	30	M36	405	410	55	45	63.0
21 73 18	245	30	M36	675	680	55	45	89.0
21 74 18	245	30	M36	1300	1070	55	45	133.0
21 75 18	245	30	M36	1575	1345	55	45	160.0
21 81 18	245	30	M42	305	320	65	50	58.0
21 82 18	245	30	M42	470	485	65	50	80.0
21 83 18	245	30	M42	845	860	65	50	126.0
21 84 18	245	30	M42	1430	1330	65	50	182.0
21 85 18	245	30	M42	1810	1710	65	50	228.0
21 91 18	275	36	M48	330	355	75	60	84.0
21 92 18	275	36	M48	505	530	75	60	111.0
21 93 18	275	36	M48	870	895	75	60	164.0
21 94 18	275	36	M48	1515	1395	75	60	243.0
21 95 18	275	36	M48	1885	1765	75	60	296.0

Order details:

Spring hanger type 21 ...

Marking:...

Operating load/Set load: ...kN

Working travel:

... mm up/down

SPRING HANGER TYPE 22

2

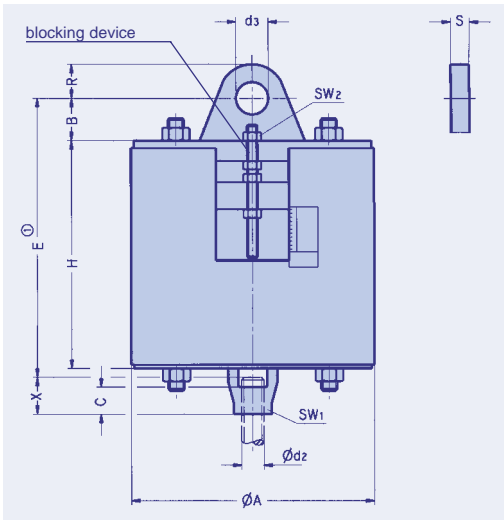

**Spring hangers
type 22 11 19 to 22 53 19**

Type	ØA	B	C	Ød2	Ød3	E ①	H	R	S	SW1	SW2	X	Weight (kg)
22 11 19	525	80	60	M56x4	62	440	350	90	30	85	46	65	240
22 12 19	525	80	60	M56x4	62	560	470	90	30	85	46	65	270
22 13 19	525	80	60	M56x4	62	840	750	90	30	85	46	65	340
22 21 19	545	95	70	M64x4	72	475	370	105	30	95	46	75	285
22 22 19	545	95	70	M64x4	72	595	490	105	30	95	46	75	320
22 23 19	545	95	70	M64x4	72	875	770	105	30	95	46	75	410
22 31 19	590	95	75	M68x4	72	490	385	105	30	100	46	80	360
22 32 19	590	95	75	M68x4	72	610	505	105	30	100	46	80	405
22 33 19	590	95	75	M68x4	72	890	785	105	30	100	46	80	510
22 41 19	625	115	80	M72x4	82	555	430	120	35	105	55	85	455
22 42 19	625	115	80	M72x4	82	685	560	120	35	105	55	85	515
22 43 19	625	115	80	M72x4	82	955	830	120	35	105	55	85	625
22 51 19	645	140	90	M80x4	92	630	480	135	35	115	65	95	550
22 52 19	645	140	90	M80x4	92	800	650	135	35	115	65	95	655
22 53 19	645	140	90	M80x4	92	1175	1025	135	35	115	65	95	865

① Dim E increases under load by the corresponding spring travel (see load table on page 2.4).

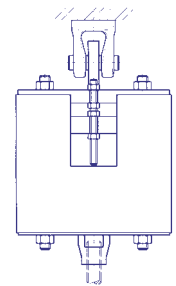

Spring hanger type 22 with weld-on clevis mounted.

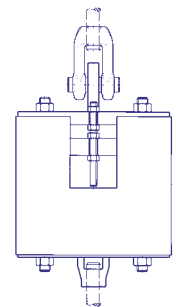

Spring hanger type 22 with clevis mounted.

◀ Application in practice

Order details:
Spring hanger type 22 ...
Marking: ...
Operating load/Set load: ...kN
Working travel:
... mm up/down



SPRING HANGER TYPE 25

Spring hangers (seated)
type 25 D2 19 to 25 93 18

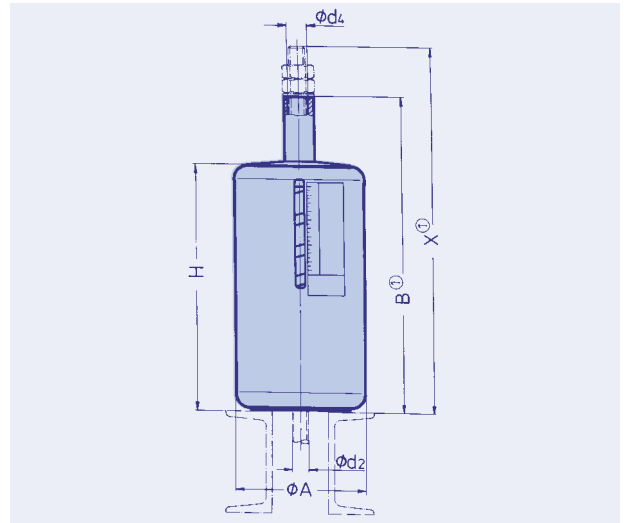

Base plate
Type 72 can be added to
type 25 on request.

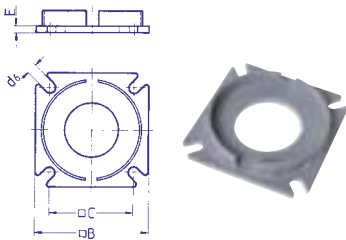

Type	B	C	d ₆	E
72 D9 28	125	95	12	8
72 19 28	125	95	12	8
72 29 28	150	115	14	10
72 39 28	150	115	14	12
72 49 28	190	140	18	12
72 59 28	220	170	18	12
72 69 28	260	200	23	15
72 79 28	290	215	23	20
72 89 28	290	215	27	20
72 99 28	340	255	33	25

↳ Load group

Type	ØA	B ^①	Ød ₂	Ød ₄	H	X max ^①	Weight (kg)
25 D2 19	90	350	M10	13	245	380	2.8
25 D3 19	90	675	M10	13	470	705	4.9
25 11 18	90	200	M12	13	145	230	2.1
25 12 18	90	350	M12	13	245	380	3.1
25 13 18	90	675	M12	13	470	705	5.5
25 21 18	115	205	M12	13	150	235	3.5
25 22 18	115	355	M12	13	250	385	5.1
25 23 18	115	665	M12	13	460	695	8.4
25 31 18	115	210	M16	18	155	250	3.7
25 32 18	115	355	M16	18	250	395	5.3
25 33 18	115	675	M16	18	470	715	8.9
25 41 18	155	230	M20	25	180	280	8.0
25 42 18	155	395	M20	25	290	445	11.5
25 43 18	155	730	M20	25	525	780	18.6
25 51 18	180	265	M24	28	215	325	14.5
25 52 18	180	405	M24	28	305	465	18.0
25 53 18	180	740	M24	28	540	800	29.0
25 61 18	220	300	M30	34	245	375	26.0
25 62 18	220	465	M30	34	360	540	35.0
25 63 18	220	845	M30	34	640	920	56.0
25 71 18	245	350	M36	40	300	440	40.0
25 72 18	245	530	M36	40	430	620	53.0
25 73 18	245	900	M36	40	700	990	79.0
25 81 18	245	385	M42	47	335	495	44.0
25 82 18	245	605	M42	47	500	715	66.0
25 83 18	245	1075	M42	47	875	1185	111.0
25 91 18	275	415	M48	54	370	535	67.0
25 92 18	275	645	M48	54	545	765	92.0
25 93 18	275	1110	M48	54	910	1230	143.0

① Dims B and X reduce under load by the corresponding spring travel (see load table on page 2.3)



For special applications spring hangers type 25 can be manufactured as trapeze units.

Order details:

Spring hanger type 25 ...

Marking: ..

Operating load/Set load: ...kN

Working travel:

... mm up/down

SPRING HANGER TYPE 26

2

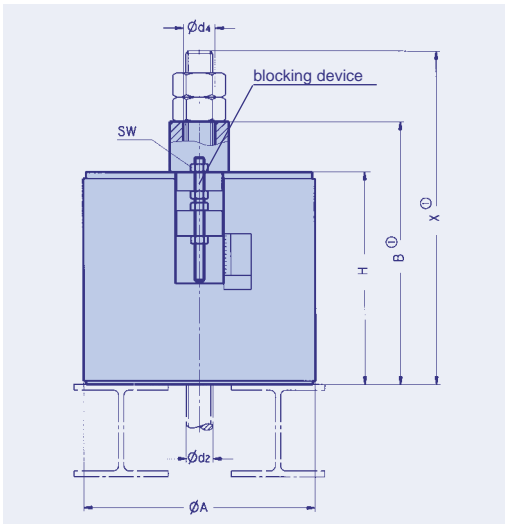

**Spring hanger (seated)
type 26 11 19 to 26 53 19**

Type	ØA	B ^①	Ød2	Ød4	H	SW	X max ^①	Weight (kg)
26 11 19	510	395	M56x4	60	345	46	530	205
26 12 19	510	565	M56x4	60	465	46	700	235
26 13 19	510	945	M56x4	60	745	46	1080	310
26 21 19	560	405	M64x4	70	355	46	560	265
26 22 19	560	575	M64x4	70	475	46	730	300
26 23 19	560	955	M64x4	70	755	46	1110	390
26 31 19	610	420	M68x4	70	370	46	585	345
26 32 19	610	590	M68x4	70	490	46	755	390
26 33 19	610	970	M68x4	70	770	46	1135	490
26 41 19	610	470	M72x4	80	420	55	645	395
26 42 19	610	650	M72x4	80	550	55	825	450
26 43 19	610	1025	M72x4	80	825	55	1200	555
26 51 19	610	530	M80x4	90	480	65	725	465
26 52 19	610	750	M80x4	90	650	65	945	545
26 53 19	610	1220	M80x4	90	1020	65	1415	725

^① Dims B and X reduce under load by the corresponding spring travel (see load table on page 2.4)



Special spring assemblies for boiler support.

Order details:
Spring hanger type 26 ...
Marking: ..
Operating load/Set load: ...kN
Working travel:
... mm up/down

SPRING SUPPORT TYPE 29

Spring supports type 29 C2 19 to 29 93 18

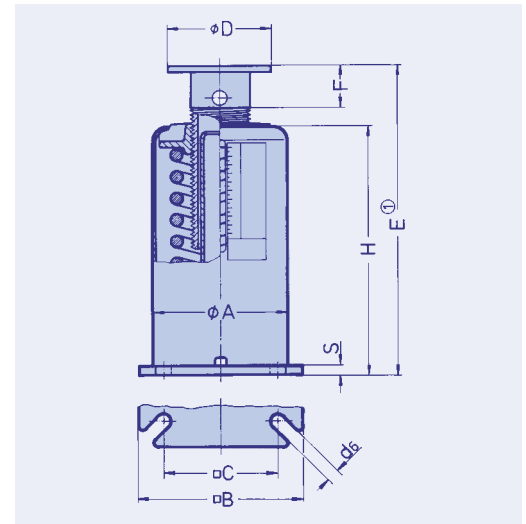
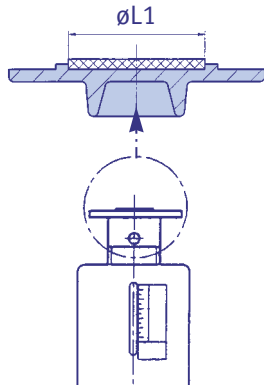

Type	Load group	$\varnothing L1$
70 19 16	C, D, 1	40
70 39 16	2, 3	40
70 49 16	4	65
70 59 16	5	65
70 69 16	6	110
70 79 16	7	110
70 89 16	8	150
70 99 16	9	150

PTFE (Teflon) slide plates are recommended for considerable horizontal load displacements.

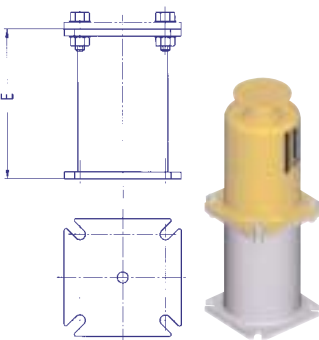

Type 29 .9 15 - E...
➔ Load group

Suitable extensions can be ordered to bridge greater installation heights.

Type	$\varnothing A$	$\square B$	$\square C$	$d6$	E ①	F	H	$\varnothing D$	S	Weight (kg)
29 C2 19	80	105	75	10	270	36	210	80	6	2.6
29 D1 19	90	125	95	12	195	36	145	80	8	3.2
29 D2 19	90	125	95	12	305	36	245	80	8	4.3
29 D3 19	90	125	95	12	550	36	470	80	8	6.6
29 11 18	90	125	95	12	195	36	145	80	8	3.4
29 12 18	90	125	95	12	305	36	245	80	8	4.6
29 13 18	90	125	95	12	550	36	470	80	8	7.2
29 21 18	115	150	115	14	200	36	150	100	10	5.6
29 22 18	115	150	115	14	310	36	250	100	10	7.6
29 23 18	115	150	115	14	540	36	460	100	10	11.1
29 31 18	115	150	115	14	205	36	155	100	12	6.3
29 32 18	115	150	115	14	310	36	250	100	12	8.4
29 33 18	115	150	115	14	550	36	470	100	12	13.0
29 41 18	155	190	140	18	240	48	180	120	12	11.9
29 42 18	155	190	140	18	360	48	290	120	12	16.0
29 43 18	155	190	140	18	615	48	525	120	12	25.0
29 51 18	180	220	170	18	270	50	210	150	12	20.0
29 52 18	180	220	170	18	370	50	300	150	12	24.3
29 53 18	180	220	170	18	625	50	535	150	12	37.0
29 61 18	220	260	200	23	305	50	245	170	15	34.0
29 62 18	220	260	200	23	430	50	360	170	15	44.0
29 63 18	220	260	200	23	730	50	640	170	15	68.0
29 71 18	245	290	215	23	360	52	300	200	20	53.0
29 72 18	245	290	215	23	500	52	425	200	20	68.0
29 73 18	245	290	215	23	790	52	695	200	20	97.0
29 81 18	245	290	215	27	400	55	335	200	20	60.0
29 82 18	245	290	215	27	575	55	500	200	20	84.0
29 83 18	245	290	215	27	965	55	870	200	20	133.0
29 91 18	275	340	255	33	440	60	370	240	25	91.0
29 92 18	275	340	255	33	625	60	545	240	25	118.0
29 93 18	275	340	255	33	1010	60	910	240	25	173.0

Order details: Spring support type 29
Marking: ..
Operating load/Set load: ...kN
Working travel: ... mm up/down

① Dim E is independent of the load setting. It varies under load by the corresponding spring travel (see load table page 2.3). Adjustment possibility +30mm.

SPRING SUPPORT TYPE 28

2

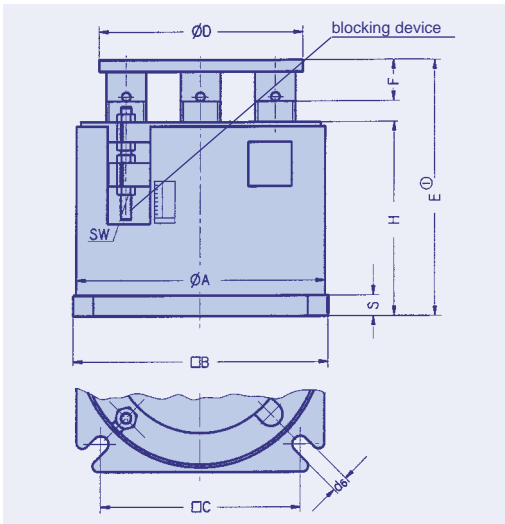

**Spring supports
type 28 11 19 to 28 53 19**

Type	ØA	□B	□C	ØD	d6	E ^①	F	H	S	SW	Weight (kg)
28 11 19	510	530	440	420	33	405	60	330	25	46	230
28 12 19	510	530	440	420	33	535	60	450	25	46	260
28 13 19	510	530	440	420	33	835	60	730	25	46	360
28 21 19	560	580	490	420	33	450	65	370	25	46	310
28 22 19	560	580	490	420	33	585	65	500	25	46	350
28 23 19	560	580	490	420	33	880	65	775	25	46	460
28 31 19	610	630	530	450	33	460	65	380	25	46	380
28 32 19	610	630	530	450	33	595	65	510	25	46	430
28 33 19	610	630	530	450	33	890	65	785	25	46	555
28 41 19	610	630	530	450	39	505	70	425	30	55	440
28 42 19	610	630	530	450	39	685	70	595	30	55	520
28 43 19	610	630	530	450	39	1075	70	965	30	55	740
28 51 19	610	630	530	480	39	560	75	475	35	65	495
28 52 19	610	630	530	480	39	750	75	655	35	65	580
28 53 19	610	630	530	480	39	1135	75	1020	35	65	785

① Dim E is independent of the load setting. It varies under load by the corresponding spring travel (see load table page 2.4).
Adjustment possibility + 30mm.



Application in practice

Order details:
Spring support type 28
Marking: ..
Operating load/Set load: ...kN
Working travel:
... mm up/down

ANGULATING SPRING SUPPORT TYPE 20

Angulating spring supports type 20 D2 19 to 20 92 14

Weld-on brackets type 35
are foreseen as connection
parts (see page 3.8).

① Dim E is independent of the
load setting. It varies under load
by the corresponding spring travel
(see load table, page 2.3).
Adjustment possibility + 50mm.

② Connection type

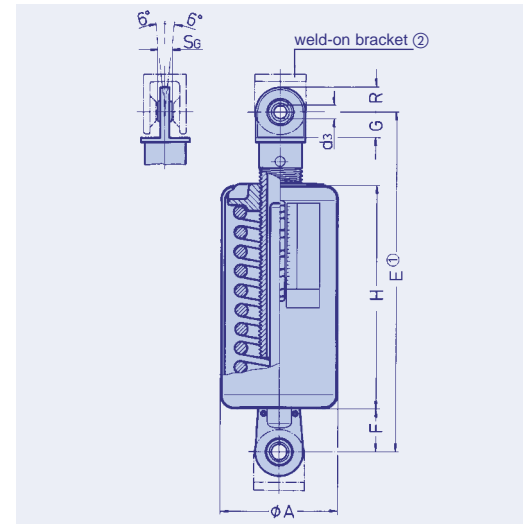

Order details:

Angulating spring support
type 20 ... with 2 weld-on
brackets 35 ...

Marking: ..

Operating load/Set load: ...kN

Working travel:

... mm up/down

Type	ØA	Ød3	E①	F	G	H	R	SG	Weight (kg)	Weld-on bracket ②
20 D2 19	90	10	370	45	15	260	15	9	4	35 29 13
20 12 14	90	10	370	45	15	260	15	9	4	35 29 13
20 22 14	115	12	380	50	19	260	20	10	7	35 39 13
20 32 14	115	15	390	58	21	260	23	12	7	35 49 13
20 42 14	155	15	440	58	21	300	23	12	15	35 49 13
20 52 14	180	20	470	65	31	315	30	16	24	35 59 19
20 62 14	220	20	535	65	31	370	30	16	45	35 59 19
20 72 14	245	30	650	100	50	430	45	22	70	35 69 19
20 82 14	245	30	735	100	52	505	45	22	87	35 69 19
20 92 14	275	50	815	130	62	550	60	35	120	35 79 19

Installation extension for angulating spring support type 20 D9 19 to 20 99 14

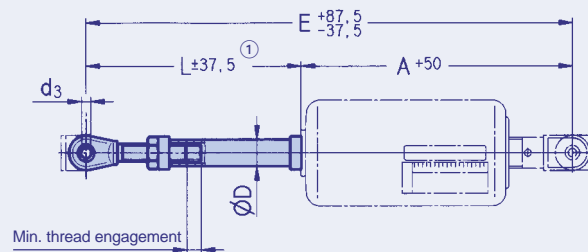

① Installation dimensions greater
than E_{max} on load reduction possible.
Shorter L dimensions can be
supplied, but then without adjustment
possibility of ± 37.5mm.

Order details:

Extension for angulating
spring support
type 20 .9 ..
L=... mm

Type	A ⁺⁵⁰	ØD	Ød3	E ^{+87.5} -37.5 min	E ^{+87.5} -37.5 max	L ^{±37.5} min①	L ^{±37.5} max	weight at L _{min} (kg)	weight tube (kg/m)
20 D9 19	325	42	10	525	1220	200	895	1.1	3.8
20 19 14	325	42	10	525	1220	200	895	1.1	3.8
20 29 14	330	48	12	535	1465	205	1135	1.3	4.4
20 39 14	332	60	15	547	1460	215	1128	2.5	8.4
20 49 14	382	60	15	597	1460	215	1078	2.5	8.4
20 59 14	405	76	20	675	1950	270	1545	8.0	14.6
20 69 14	470	76	20	740	1950	270	1480	8.0	14.6
20 79 14	550	89	30	835	1925	285	1375	10.6	21.1
20 89 14	635	89	30	920	2425	285	1790	10.6	21.1
20 99 14	685	102	50	1015	2410	330	1725	16.5	30.6

SPRING HANGER TRAPEZES TYPE 79

2

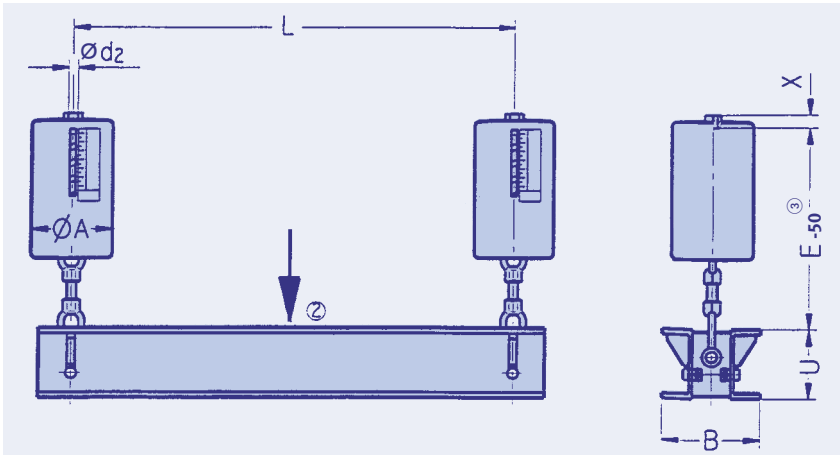

Trapeze Type	Nominal load (kN) ②	Ød2	L max	E ③ at Travel range			U	A	B	X	Weight (kg) L= 1000 at travel range			±per 100 mm
				1	2	3					1	2	3	
79 D. ① 19	1.25	M10	1700	-	385	610	80	90	140	15	-	26	30	1.7
79 1. 19	2.5	M12	1700	290	385	610	80	90	140	15	24	26	31	1.7
79 2. 19	5	M12	1700	290	390	610	80	115	140	15	28	31	37	1.7
79 3. 19	10	M16	900	315	410	630	80	115	140	20	29	32	39	1.7
79 3. 19	10	M16	1800	300	395	615	120	115	190	20	41	45	52	2.7
79 4. 19	20	M20	1400	345	450	685	120	155	190	25	53	60	74	2.7
79 4. 19	20	M20	1800	345	450	685	140	155	200	25	61	68	82	3.2
79 5. 19	40	M24	1250	405	495	730	140	180	200	30	77	85	108	3.2
79 5. 19	40	M24	1800	390	480	715	180	180	230	30	93	101	124	4.4
79 6. 19	80	M30	1250	445	560	840	200	220	250	35	138	156	200	5.1
79 6. 19	80	M30	2400	435	550	830	260	220	310	35	174	192	236	7.6
79 7. 19	120	M36	1800	505	630	900	260	245	310	45	214	244	296	7.6
79 7. 19	120	M36	2400	500	625	895	300	245	350	45	245	275	327	9.2
79 8. 19	160	M42	1200	560	725	1100	260	245	310	50	242	286	378	7.6
79 8. 19	160	M42	1800 ④	555	720	1095	300	245	350	50	273	317	410	9.2
79 9. 19	200	M48	1800 ④	610	785	1150	300	275	350	60	335	390	495	9.2

① The 4th digit of the type designation denotes the travel range of the spring hanger. 1=50mm, 2=100mm, 3=200mm

② Permissible center load of the other load conditions see table 3.5.3 page 0.5 (Nominal load 120 kN see load group 9)

③ Dim E increases under load by the corresponding spring travel (see load table on page 2.3)

④ The maximum L dimensions may be increased to 2400mm, with load reduction of 5% for each 100mm of extension.

Order details:

Trapeze, type 79 .. 19
L= ... mm

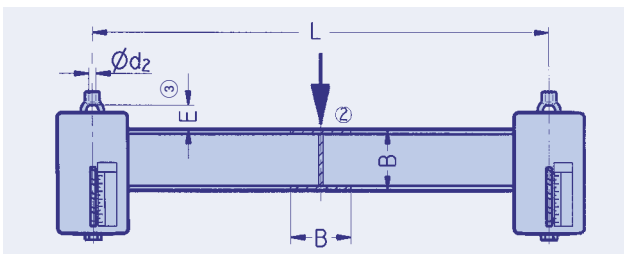

travel range ①	E dimension approx. ③
1	30
2	55
3	105

Notes ①...③ see above

Trapeze Type	Nominal load (kN) ②	Ød2	L max	B	Weight (kg) L= 1000mm at travel range			±per 100mm (kg)
					1	2	3	
79 D. ① 11	1.25	M10	1400	80	-	16	20	1.1
79 1. 11	2.5	M12	1400	100	19	21	26	1.6
79 2. 11	5	M12	1600	100	26	29	35	2.0
79 3. 11	10	M16	1600	100	27	30	38	2.0
79 4. 11	20	M20	1750	120	41	48	63	2.7
79 5. 11	40	M24	2100	160	68	76	99	4.3
79 6. 11	80	M30	2100	200	110	128	172	6.1
79 7. 11	120	M36	2100	240	159	189	241	8.3
79 8. 11	160	M42	2150	260	186	230	322	9.3
79 9. 11	200	M48	2200	280	243	297	403	10.3

Spring Hanger trapezes type 79 .. 11

For restricted spaces the design shown can be manufactured as a special.

Order details:

Trapeze type 79 .. 11
L= ... mm

SWAY BRACE TYPE 27

**Sway brace
type 27 D2 19 to 27 62 19**
Maximum working travel
25mm including free stroke

- ① Load setting is carried out at the works in accordance with customer specifications.
- ② Dim E is independent of load setting. Adjustment possibility ± 37.5 mm.
- ③ Weld-on brackets type 35 and dynamic pipe clamps type 36 or 37 are foreseen as connection parts.

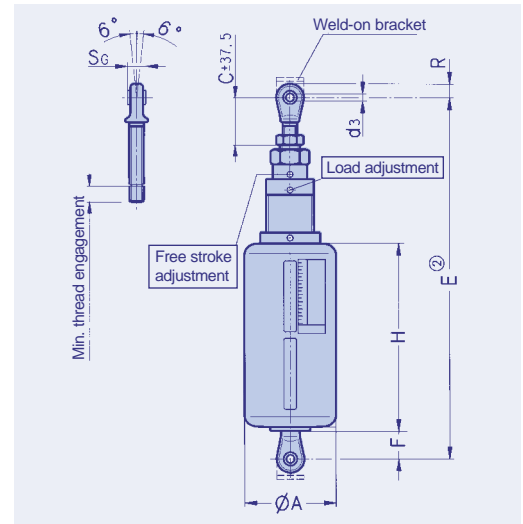

Order details:

Sway brace type 27 .2 19
Marking: ...
Operating load/Set load: ...kN
Working travel:
... mm up/down

Type	Nom. load (kN)	Calibr. load min [kN]	Calibr. load max [kN]	Spring rate (N/mm)	ØA	C±37.5	Ød3	E②	F	H	R	SG	weld-on bracket Type ③	Weight (kg)
27 D2 19	0.52	0.12	0.42	4.1	90	90	10	640	50	295	15	9	35 29 13	5.5
27 12 19	1.25	0.41	1.04	8.3	90	90	10	640	50	295	15	9	35 29 13	5.8
27 22 19	2.50	0.83	2.08	16.6	115	90	12	650	50	300	19	10	35 39 13	10
27 32 19	5.00	1.66	4.16	33.3	115	90	15	665	55	305	21	12	35 49 13	11
27 42 19	10.00	3.33	8.33	66.6	155	90	15	730	55	355	21	12	35 49 13	23
27 52 19	20.00	6.66	16.66	133.3	180	100	20	810	75	380	30	16	35 59 19	39
27 62 19	40.00	13.33	33.33	266.6	220	100	20	875	75	445	30	16	35 59 19	62

**Extension for sway brace
type 27 D9 19 to 27 69 19**

If requested, sway braces can be supplied with shop-fitted extensions

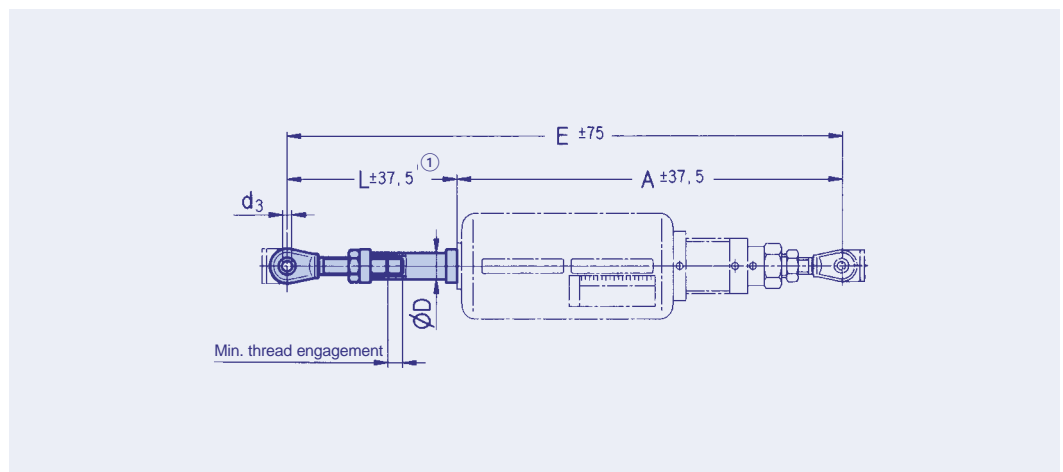

① Installation dimensions greater than E_{max} on load reduction possible. Shorter L dimensions can be supplied, but then without adjustment possibility of ± 37.5 mm.

Order details:

Extension for sway brace
type 27 .9 19
L-dim.: ... mm

Type	A ± 37.5	ØD	Ød3	E ± 75 min	E ± 75 max	L ± 37.5 ① min	L ± 37.5 ① max	Weight at L _{min} (kg)	Weight tube (kg/m)
27 D9 19	590	42	10	790	1600	200	1010	1.1	3.8
27 19 19	590	42	10	790	1600	200	1010	1.1	3.8
27 29 19	600	48	12	805	2000	205	1400	1.3	4.4
27 39 19	610	60	15	825	2000	215	1390	2.5	8.4
27 49 19	675	60	15	890	2000	215	1325	2.5	8.4
27 59 19	735	76	20	1005	2400	270	1665	8.0	14.6
27 69 19	800	76	20	1070	2400	270	1600	8.0	14.6

Function diagram

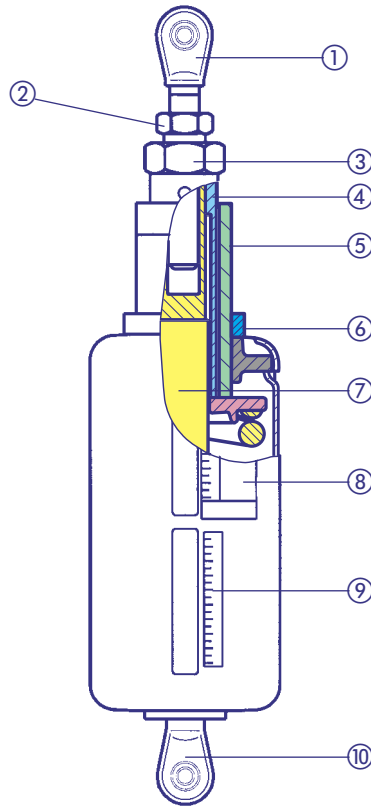
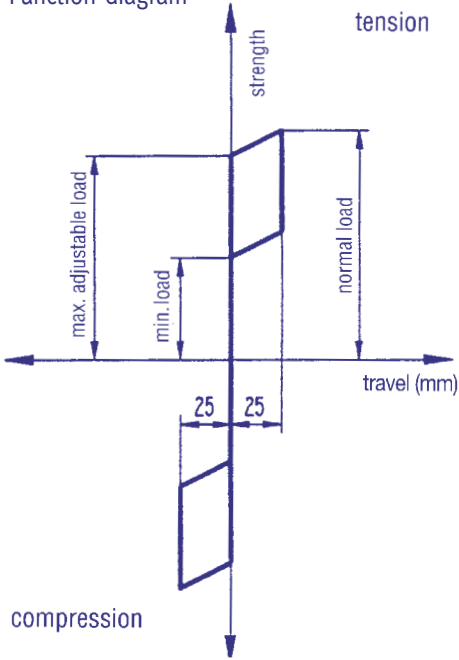

Load and installation length are adjustable to the corresponding specifications.

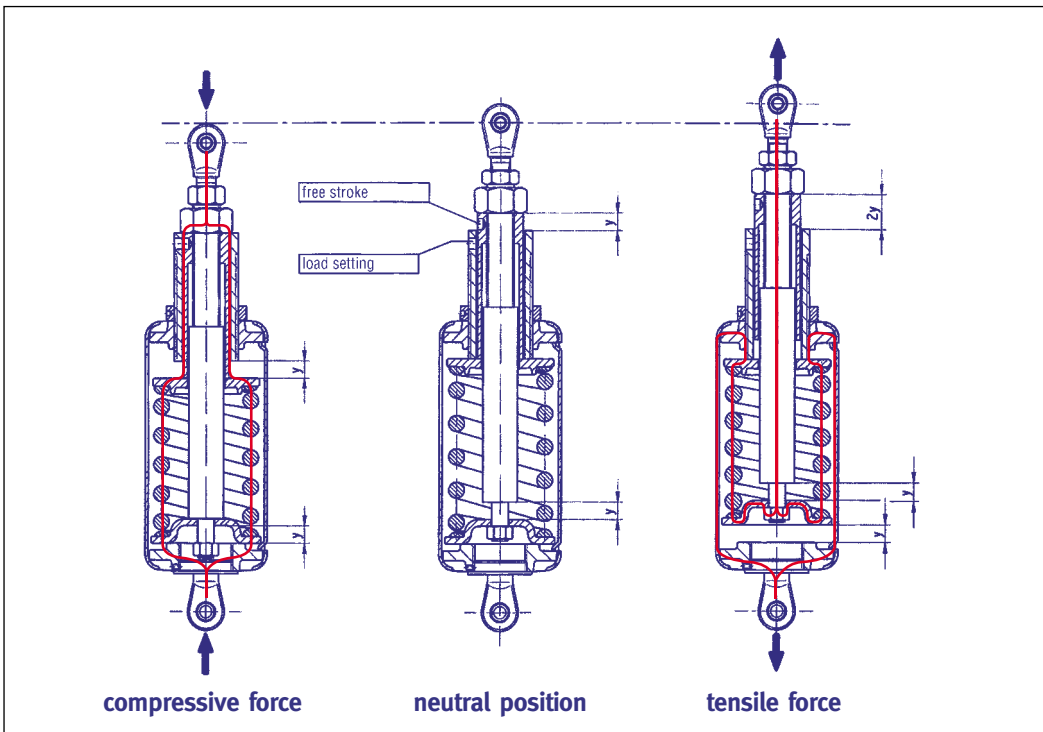

Transfer of force on alternating direction of force.

INSTALLATION AND OPERATING INSTRUCTIONS

Spring hangers and supports are used to compensate for the thermal movement to be expected in piping systems. For trouble-free functioning, correct installation is essential, observing the following instructions:



Spring hanger, type 21 (blocked)



Spring hanger, type 25 (blocked)



Spring support, type 29 (blocked)

Spring hangers and spring supports types 20, 21, 22, 25, 26, 27, 28, 29

1. Transport and storage

When transporting, threaded connections and travel stops must not be damaged. When stored in the open they should be protected from dirt and moisture.

2. Delivery condition

Unless agreed otherwise, spring hangers and spring supports are delivered to the site blocked in the installation position. When hangers or supports are blocked (travel stop in both directions), the spring plate is locked by a special blocking device in the housing slots.

All spring hangers and supports are supplied with a riveted aluminum name plate fitted with an integral travel scale. The following information is stamped on the name plate:

- order number if required
- set load
- theoretical travel
- spring rate of the hanger or support
- marking and position number
- test stamp if required

The serial number is stamped directly on the housing.

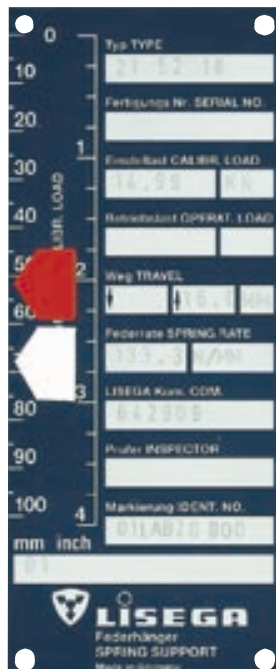

Name plate for spring hanger

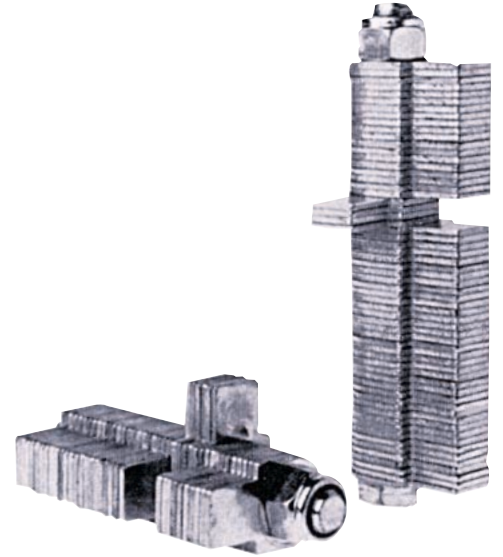

The blocking units for single spring models consist of a set of hinged metal plates. Individual plates can be swivelled into any desired blocking position.

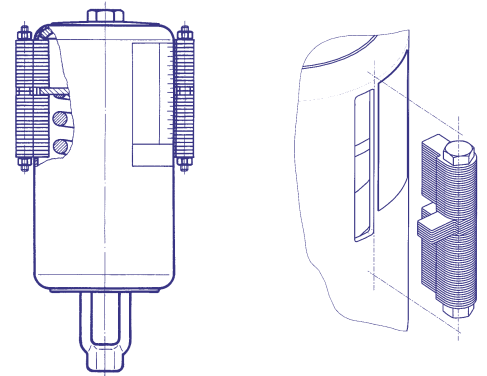

Blocking device for single spring models

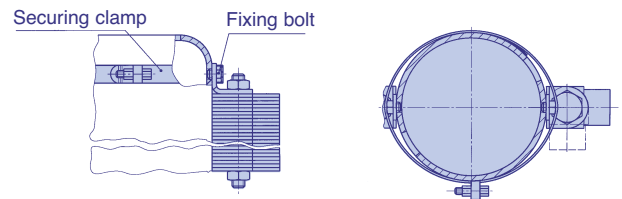

If specially ordered, the stops can be bolted securely to the hanger or support after deblocking.

- ① upper connection
- ② travel scale
- ③ blocking unit with securing band
- ④ name plate
- ⑤ lower connection (turnbuckle with right-hand thread)
- ⑥ counter nut



Load chain with spring hanger

On the travel scale, the theoretical operating position is marked with a red, and the theoretical cold position with a white sticker. Also, the position of the spring plate is marked with an X on the travel scale. The read out is made at the bottom edge of the spring plate.

2.1 Spring hangers, type 21

Spring hangers, type 21, have upper and lower connections fitted with right-hand threads. At the top they consist of an internal thread engagement of limited depth, and at the bottom a turnbuckle. The threads are filled with grease and sealed with plastic caps.

2.2 Spring hangers, type 22

The upper connection of these hangers is supplied as a lug for a connecting pin. The lower connection consists of a turnbuckle with righthand thread.

2.3 Spring hangers, type 25 & 26

Spring hangers, type 25 & 26 are provided with a fixed support tube to accommodate the connecting rod.

2.4 Spring supports, type 28 & 29

The spring supports are provided with either one or four adjustable support tubes fitted with a loosely mounted, but guided load plate. The support tubes are screwed in and the threads greased.

2.5 Angulating spring supports, type 20

The angulating spring supports are provided at the top with an adjustable support tube and a rotatable ball bushing joint, at the bottom with a fixed ball bushing joint. The joints provide a suitable connection to the corresponding weld-on brackets type 35. The support tube is screwed in and the threads greased.

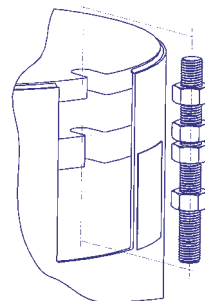

Blocking device for heavy duty spring elements type 22 to 28



Angulated spring support, type 20



Spring hanger, type 22



Spring hanger, type 26



Spring support, type 28



Sway brace, type 27

2.6 Sway braces, type 27

Sway braces are provided at the top with a length-adjustable ball bushing joint and at the bottom with a fixed lug suitable for connection to weld-on bracket type 35 or dynamic clamp type 36 or 37. Presetting of the load and if necessary the free stroke are carried out at the works in accordance with customer requirements.

3. Installation

When installing, the rules given in **Installation Instructions for Piping** must also be observed. Special care must also be given to the installed position of the connecting rods over the whole support chain. Two possibilities are the norm:

1. The connecting rods are to be installed at an angle corresponding to the horizontal displacement to be expected. A vertical position of the rods is expected under normal operating conditions.
2. The connecting rods are to be installed vertically for easier checking. A controlled angled position under normal operating conditions is thereby permitted.

In each case there should be unified rules and regulations for the whole plant.

Connecting rods and points must be actuated by load at connection points.

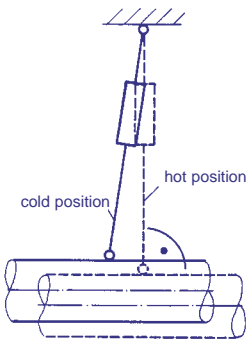

Case 1
Attachment rods vertical during plant operation

3.1 Spring hangers, type 21

Connection is made by screwing the connecting rod into the upper threaded connection hole in type 21, and by screwing the lower connecting rod into the turnbuckle. As a tension range and length adjustment, the turnbuckle length available in the hanger can be used for the connecting rod.

3.2 Spring hanger, type 22

Connection is made by pinning the lug to the upper attachment point and by screwing the lower connecting rod into the turnbuckle. As a tension range and length adjustment, the turnbuckle length available in the hanger can be used for the connecting rod.

3.3 Spring hangers, type 25 & 26

These spring hangers are set on beams and correspondingly positioned. Once the precise position is defined the unit should be secured against horizontal movement. The load actuated connection is made via the connecting rod, which is led through the support tube and tightened with a nut.

3.4 Spring supports, type 28 & 29

After positioning, these spring supports are connected to the structure by bolting or welding the base plate to the structure. Load distribution is applied through the load plate or through one or more adjustable load tubes.

3.5 Angulating spring supports, type 20

The angulating spring supports are connected to the structure after corresponding positioning by welding the lower weld-on bracket. Load distribution is applied through the upper weld-on bracket via the pin connection to the height-adjustable load tube.

3.6 Sway braces, type 27

After positioning of the connection points, the weld-on brackets are attached and connection is made through the connection pins of the brackets or dynamic clamps. The ball bushing joints allow a $\pm 37.5\text{mm}$ adjustment of installation length.

4. Removing the travel stops

The spring hangers and supports should only be deblocked when the set load is fully applied to all the supports, which form one system. If this is the case, the travel stops can easily be removed. If the travel stops are jammed, the load actually applied does not correspond with the theoretical adjusted load. (See **Installation and Operating Instructions, Constant Hangers**, page 1.23, item 4, in this regard).

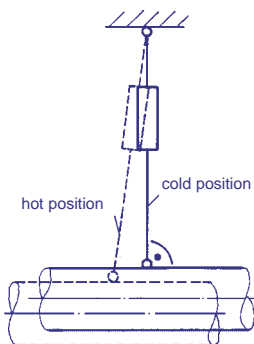

Case 2
Attachment rods vertical in installation condition

5. Load readjustment

5.1 Spring hangers, spring supports

For spring hangers the load can be readjusted by loosening or tightening the threaded rods at the lock nut. For spring supports, the load can be readjusted by a corresponding adjustment of the load tube.

Under all circumstances, however, the appropriate technical department must be consulted before attempting any load readjustment.



Example of an arrangement with type 25

5.2 Sway braces, type 27

Load readjustment is made by rotating the threaded tube (A). The large counter ring (B) is loosened to do this. In order to maintain the E dimension, the resulting gap is compensated for by readjustment of the guide tube.

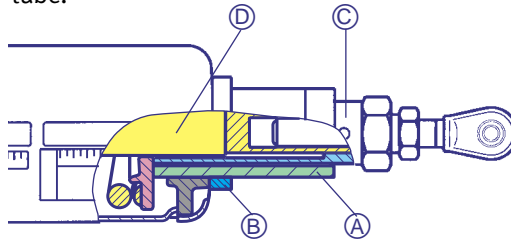

For sway braces, a free stroke can be set. To do this, the guide tube (C) opposite the inner guide rod (D) is to be unscrewed (loosen middle lock nut). The working travel reduces in the compression direction in accordance with the free stroke selected.

6. Commissioning

Before commissioning it must be checked that each hanger or support allows the pre-calculated movement of the piping. The working travel of the hanger or support can be read off at the bottom edge of the spring plate as travel in the blocking slots, and read directly off the travel scale.

7. Checking and maintenance

The correct functioning of the spring hangers or supports can be checked in all operating situations by noting the position of the spring plates.

Under normal operating conditions no maintenance is required.

- ① connecting rod
- ② counter nut
- ③ lock nut
- ④ load tube
- ⑤ travel stop
- ⑥ travel scale
- ⑦ name plate

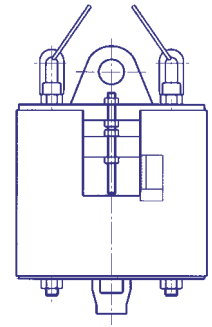

Spring hanger type 22 with eye nuts as transport lugs

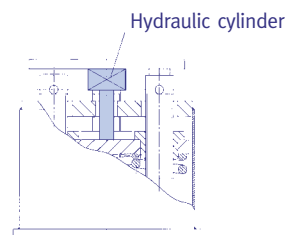
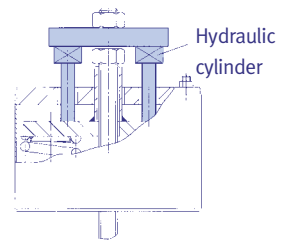
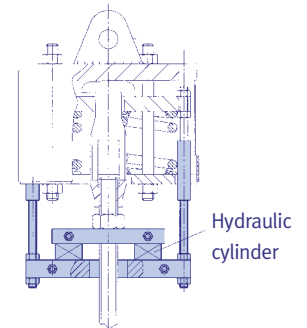

Installation devices for readjustment of the set load for types 22, 26 and 28. The devices can equally well be used as deblocking aids.